Foreword

This service manual is the result of the dedication of The Dometic Corporation and its engineers in giving service people the necessary instruction for making accurate analyses of certain conditions. Provided is a diagnostic chart leading a qualified mechanic into the service manual pages to locate and solve symptoms which may occur. Dometic has continued its commitment in providing service people with this, the most up-to-date information about servicing Dometic RV accessories.

CONTENTS

PAGE NO.

RM2604 & 2804 STD DIAGNOSTIC FLOW CHART	1
---	---

SECTION 1

AC VOLTAGE REQUIREMENTS	3
-----------------------------------	---

SECTION 2**AC COMPONENTS**

2.1 Heating Element	3
2.2 Thermostat	3

SECTION 3

DC VOLTAGE REQUIREMENTS	3
-----------------------------------	---

SECTION 4**DC COMPONENTS**

4.1 Switch	3
4.2 Igniter	4
4.3 Electrode	4
4.4 High Voltage Cable	4
4.5 Door Switch	5
4.6 Relay	5
4.7 Heating Element	5

SECTION 5

LP GAS REQUIREMENTS	5
-------------------------------	---

SECTION 6**LP GAS COMPONENTS**

6.1 Shut-Off Valve	6
6.2 Filter	6
6.3 Thermostat	6
6.4 By-pass Screw	6
6.5 Safety Valve	7
6.6 Thermocouple	7
6.7 Burner	7
6.8 Flue Baffle	7
6.9 Flue Cap	7
6.10 Flue Tube	7
6.11 Orifice	7

SECTION 7**WIRING**

7.1 External Wiring	7
7.2 Internal Wiring	8

SECTION 8**OTHER**

8.1 Leveling	9
8.2 Ventilation	9
8.3 Air Leaks	10
8.4 Door Position	10
8.5 Ambient Temperature	10
8.6 Cooling Unit	11
8.7 Food Storage	11
8.8 High Humidity	11
8.9 Interior Liner Seal to Frame	11

This program will address the most common system problems associated with the RM2604/2804 Manual Refrigerators supplied by The Dometic Corporation. Our intent is to provide you with a guideline of checks to make, should you encounter one of the following symptoms.



SYMPTOM	CAUSE	REFER TO SECTION	STEP
1. No operation.	DC Volts Wiring Switch	3 7 4.1	
2. No electric operation.	AC Volts Heating Element Thermostat Switch Wiring	1 2.1 2.2 4.1 7.2	
3. No gas operation — no spark.	DC Volts Igniter Electrode High Voltage Cable Switch Wiring	3 4.2 4.3 4.4 4.1 7.2	
4. No gas operation — sparks but no flame.	LP gas Filter Orifice Burner Shut-off Valve Safety Valve Thermocouple	5 6.2 6.11 6.7 6.1 6.5 6.6	
5. No cooling on any mode.	Level Ambient Temperature Cooling Unit	8.1 8.5 8.6	
6. No cooling on gas — cools properly on electric.	LP Gas Thermostat Filter Orifice Burner Flue Baffle Flue Tube	5 6.3 6.2 6.11 6.7 6.8 6.10	
7. No cooling on electric — cools properly on gas.	AC Volts Heating Element Thermostat Switch Wiring	1 2.1 2.2 4.1 7.2	
8. Insufficient cooling on all modes.	Level Ventilation Ambient Temperature Air Leaks Thermostats Cooling Unit	8.1 8.2 8.5 8.3 2.2 & 6.3 8.6	
9. Insufficient cooling on electric — cools properly on gas.	AC Volts Heating Elements Thermostat	1 2.1 2.2	

SYMPTOM	CAUSE	REFER TO SECTION	STEP
10. Insufficient cooling on gas. Cools properly on electric.	LP Gas Pressure Thermostat Filter Orifice Burner Flue Baffle Flue Tube	5 6.3 6.2 6.11 6.7 6.8 6.10	
11. Freezes on electric – cools properly on gas.	Thermostat Wiring	2.2 7.2	
12. Freezes on gas – cools properly on electric.	Bypass Screw Thermostat	6.4 6.3	
13. On gas mode, sparks while flame is lit.	Electrode LP Gas Bypass Screw Filter	4.3 5 6.4 6.2	
14. Won't stay lit on gas.	LP Gas Safety Valve Thermocouple Flue Baffle Flue Cap Orifice Burner	5 6.5 6.6 6.8 6.9 6.11 6.7	
15. Rapid formation of frost.	Food Storage Air Leaks Interior Liner Seal to Frame High Humidity	8.7 8.3 8.9 8.8	
16. Interior light on when door is closed.	Wiring Door Switch Door Position	7.2 4.5 8.4	
17. No DC operation – cools properly on AC and gas.	DC Volts Heating Element Switch Wiring Relay	3 4.7 4.1 7.2 4.6	
18. Insufficient cooling on DC– cools properly on AC and gas.	DC Volts Heating Element Relay	3 4.7 4.6	

SECTION 1 AC VOLTAGE REQUIREMENTS

The refrigerator is a 120-volt AC, 60 Hz appliance. The proper operating range is 100 to 132 volts. Check the AC volts at the receptacle where the refrigerator is attached. Voltage is outside of the proper operating range, correct the power source problem.

SECTION 2 AC COMPONENTS

2.1 HEATING ELEMENT

The heating element is designed to deliver a predetermined amount of heat to the cooling unit.

To check a heating element, remove the heater leads from the terminal block and measure for proper resistance across the two leads with a properly calibrated ohm meter. This check is to be done with the heating element at room temperature. The proper ohms for RM2604 is 48 and RM2804 is 44 with a tolerance of ten percent. If the resistance is outside the tolerance range, replace the heating element.

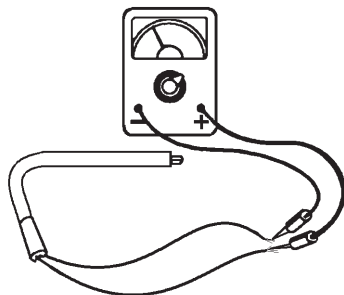

2.2 THERMOSTAT

It is an electric only thermostat. On 2-way models it controls the AC heating element. On 3-way models it controls the DC heating element as well as the AC heating element. The thermostat regulates the cabinet temperature by making and breaking the heat source circuit. The internal mechanism breaks contact (continuity) when adequate cabinet temperature has been reached. Check the thermostat for continuity or use a jumper wire with insulated clips and bypass the thermostat.

NOTE: Care should be used. Do not short to thermostat casing. Also remove the jumper after testing is completed.

If the above test allows the refrigerator to operate, replace the thermostat.

SECTION 3 DC VOLTAGE REQUIREMENTS

For the refrigerator to operate the interior light, igniter (gas mode) and DC volt operation (3-way models only), DC voltage must be supplied to the terminal block or blocks (2 terminal blocks on 3-way models) at the rear of

the refrigerator. The operational range is 10.5 to 15 volts DC. Connecting the refrigerator to an unregulated converter can result in improper operation of the refrigerator. Check for proper voltage at the terminal block or blocks at the back of the refrigerator. If power is outside the operational range, correct the power supply problem. The power supply to the refrigerator must be fused. The interior light and igniter must be on a separate circuit and will draw about 1 amp at 12 volts DC. The DC heating element (on 3-way models only) will draw 18 amps at 12 volts DC. The maximum fuse size is 25 amps for the RM2604 and RM2804.

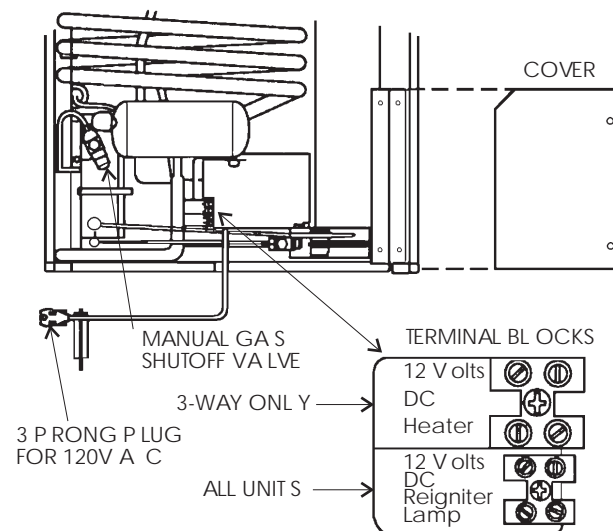

SECTION 4 DC COMPONENTS

4.1 SWITCH

This is the switch that selects the mode of operation (120 volt AC, gas and 12 volt DC). It is also a circuit interrupter for each mode of operation on the refrigerator. When the customer selects either AC, gas or DC (3-way models only) operation, the selector switch directs electricity first to the interior light and the thermostat and on to the heating element or the igniter for gas mode. When this switch is turned off, the AC or DC circuit is interrupted. To check the switch in the AC mode, continuity should exist between these terminals: 1 to 1A, 2 to 2A and 7 to 7A. To check the switch in the gas mode, continuity should exist between these terminals: 4 to 4A and 7 to 7A.

To check the switch in the DC mode (on 3-way models only), continuity should exist between these terminals: 5 to 5A, 6 to 6A and 7 to 7A.

NOTE: To do a continuity check, first be sure all power is disconnected or off to the refrigerator. Second, remove all wires from the switch. After the check, be

sure switch is wired properly per the wiring diagram (See Sec. 7.2).

When the switch is in the off position a continuity reading **SHOULD NOT** be indicated on any terminals. If the above test results are correct, **DO NOT REPLACE** the switch. If any one of the above tests are not correct **REPLACE** the switch.

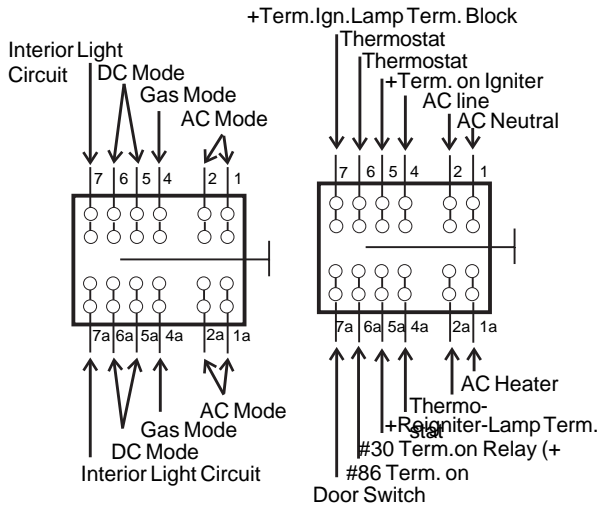

4.2 IGNITER

The igniter is an electronic device that produces high voltage to create a spark at the burner, only on gas mode. It also produces an increased DC voltage at the L terminal which is directed to the indication lamp each time a spark is produced. First, check that the switch is in the gas mode and is completing the circuit (See Sec. 4.1). Next, verify proper voltage at the positive (+) and ground (-) terminals of the igniter. The reading should be within one volt of incoming voltage at the igniter and lamp terminal block. A voltage drop of more than one volt would indicate a loose connection (See Sec. 7.2). No voltage would indicate an open circuit, check switch (See Sec. 4.1), wiring (See Sec. 7.2) and DC voltage requirements (See Sec. 3).

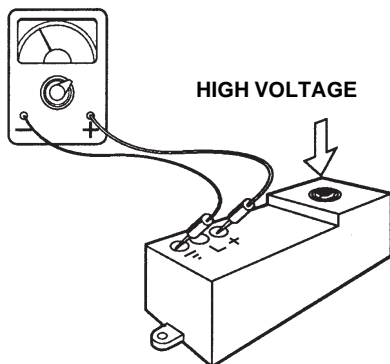

Next, disconnect DC power at the igniter, lamp terminal block. Remove high voltage cable from igniter. Reconnect DC power, the igniter should produce a sparking

sound. If not, replace the igniter. Next, with the igniter producing spark, set the meter on 20 volts DC or lower scale, connect meter leads to L and ground terminals on the igniter. The meter should read a pulsating voltage. If not, replace the igniter.

If all of the previous checks are correct, the igniter is

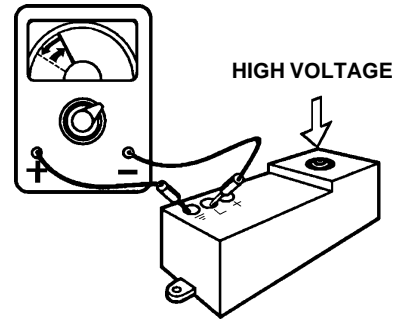

good, **DO NOT REPLACE**. The pulsating voltage allows a lamp to illuminate on the front of the refrigerator to advise the customer spark has been produced. To check the lamp, first, verify it is wired correctly. Next, verify the lamp receptacle is receiving the signal, if so, and lamp is not illuminating (flashing), replace the lamp.

NOTE: Do not supply DC power to the lamp. It will not illuminate with normal DC power. For the lamp to illuminate it must receive an increased DC signal.

4.3 ELECTRODE

To check the electrode, first do a visual inspection for cracks or breaks on the ceramic insulator. Also, verify the mounting bracket is attached properly to the electrode. If either of the above conditions are found, replace the electrode. Next, check the spark gap. It must be set at three sixteenths (3/16) of an inch and the tip of electrode above the slots in the burner.

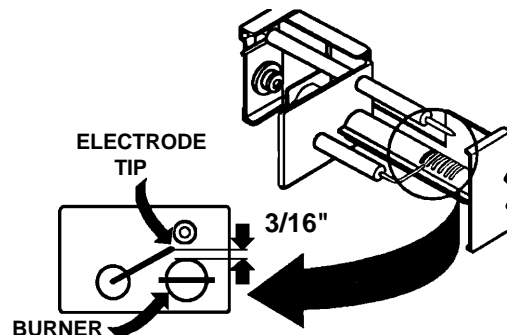

NOTE: If igniter (See Sec. 4.2) and high voltage cable (See Sec. 4.4) are good and there is no spark at the tip of the electrode, **REPLACE THE ELECTRODE**.

4.4 HIGH VOLTAGE CABLE

NOTE: Be sure switch (See Sec. 4.1) and igniter (See Sec. 4.2) are good before checking the high voltage cable and the switch is in the gas mode.

To check the high voltage cable, first disconnect DC power at the igniter, lamp terminal block. Next, disconnect high voltage cable from electrode. Then reconnect DC power to the terminal block. If sparking starts, cable is good, **DO NOT REPLACE**, check the electrode (See Sec 4.3). If no sparking, disconnect DC power at the igniter, lamp terminal block and then disconnect high voltage cable at the igniter. Reconnect DC power to the terminal block. If sparking sound from igniter, replace the high voltage cable.

4.5 DOOR SWITCH

The door switch is an open switch when the switch arm is depressed (interior light should be off). When the refrigerator door is open, the switch is closed (interior light should be on). Check that the switch assembly is properly aligned and that it is not broken. Check the switch assembly for continuity. When the switch arm is depressed there should not be continuity. When the switch arm is **NOT** depressed there should be continuity. If any of the checks are incorrect, replace the switch.

4.6 RELAY (3-WAY MODELS ONLY)

The relay controls the circuit to the DC heating element. The load (amps) of the DC heating element goes through the relay.

To check the relay, first verify the selector switch is on DC mode (See Sec. 4.1) and the thermostat (See Sec. 2.2) is **NOT** completing the circuit. Next, verify voltage is present between terminals 85 and 30. If voltage is not present, check wiring to both terminals. (See Sec. 7.2)

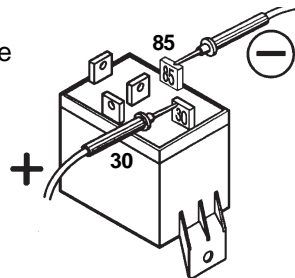

Next, check for voltage between terminals 85 and 87. If voltage is present, the relay is defective and needs to be replaced.

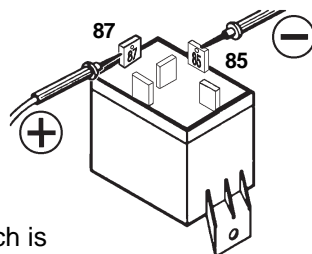

Second, verify the selector switch is on DC mode (See Sec. 4.1) and the thermostat (See Sec. 2.2) is completing the circuit.

Next, verify voltage is present between terminals 85 and 86. If no voltage is present, check wiring and connections (See Sec. 7.2).

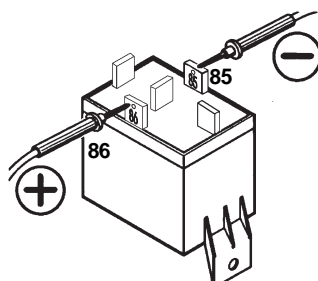

Next, if voltage is present, between 85 and 86 terminals, then voltage should be present

between terminals 85 and 87. If no voltage is present, the relay is defective, replace it.

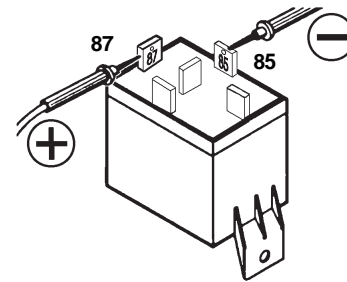

4.7 HEATING ELEMENT (3-WAY MODELS ONLY)

The heating element is designed to deliver a predetermined amount of heat to the cooling unit. Check the heating element with ohms resistance using a properly calibrated ohm meter. This check is to be done with the element at room temperature. The proper ohms for RM2604 and RM2804 DC heating element is .67 with a tolerance range of ten (10) percent. If the heating element is outside the tolerance range, replace it.

NOTE: It will take a very precise ohm meter to accurately read this measurement. If a precise ohm meter is not available, a continuity reading will indicate an open or complete circuit. If an open circuit is the test result, replace the element.

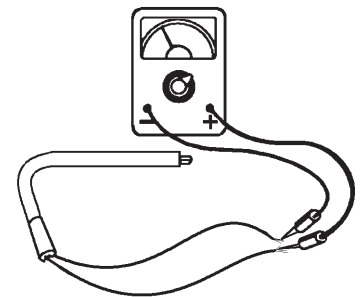

SECTION 5 LP GAS REQUIREMENTS

The LP gas pressure to the refrigerator should be 11 inches water column with half of all BTU's of the RV turned on. With all other appliances turned off, the pressure to the refrigerator should not exceed 12 inches water column. To check the gas pressure when the refrigerator is operating, there is a pressure test housing located just prior to the orifice.

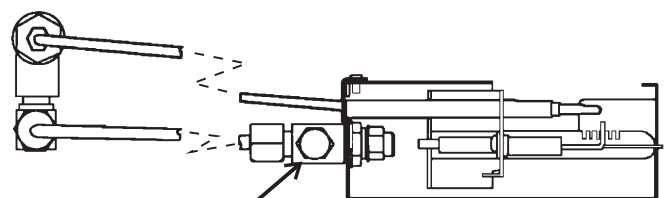

PRESSURE TEST HOUSING

SECTION 6 LP GAS COMPONENTS

6.1 SHUT-OFF VALVE

It is the valve where the incoming LP gas supply is attached. This valve is direct coupled to the selector switch. When the selector switch is turned to the electric mode, the shut-off valve is automatically closed. When this same switch is turned to the LP gas mode, the valve opens and allows gas flow and the electric circuit to the heating elements is also automatically interrupted. To check the shut-off valve, remove and inspect for any obstructions.

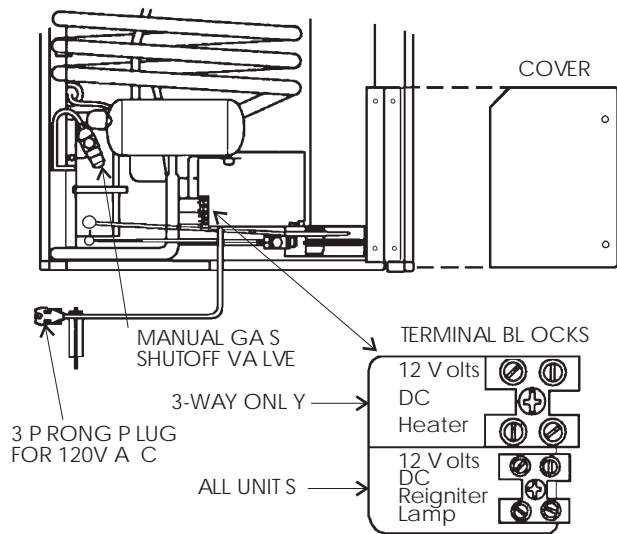

6.2 FILTER

A filter is located in the inlet fitting to the gas thermostat. It protects the internal valve portion of the thermostat by collecting any particles and/or oil that could get into the LP gas line. The filter can become saturated and cause a restriction to gas flow. This could cause a lack of cooling on gas mode. If you suspect a restriction, first verify the thermostat (See Sec. 6.3) and by-pass screw (See Sec. 6.4) are good. If these components are good, remove the filter and replace with a new one if proper gas pressure is supplied to the refrigerator and you cannot get proper gas pressure at the pressure test housing.

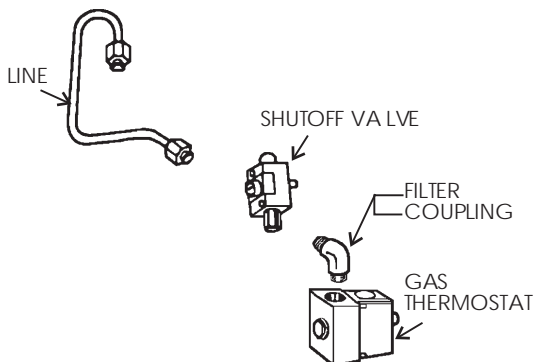

6.3 THERMOSTAT

On the LP gas mode, full line pressure is directed through the thermostat to the burner until the thermostat senses that the refrigerator cabinet has reached proper cooling temperature. At that time an internal valve closes and redirects the gas flow through the by-pass screw. This reduces the amount of LP gas going to the burner assembly. The gas flow remains in this "by-pass" mode until the thermostat senses that the refrigerator cabinet needs more cooling. Again, the thermostat directs LP gas flow through the thermostat at full line pressure until the cabinet temperature is sufficient. The thermostat is calibrated by the manufacturer so that at mid-range the cabinet temperature should be approximately 40 degrees Fahrenheit. **To check the calibration of the thermostat**, place a container of water in the cabinet of the refrigerator and operate at mid-range setting until the thermostat is satisfied. Then, check the temperature of the water. It should be approximately 40 degrees. We do not recommend any calibration in the field. If calibration is not correct, replace the thermostat. **To check the thermostat for proper gas flow**, set the thermostat to maximum and check the gas pressure at the pressure test port. It should be line pressure, between 11 to 12 inches water column. If you have less than 11 inches of water column pressure, the next step would be to shut off the gas supply and remove the by-pass screw. Then install a by-pass screw that does not have the small o-ring on it. Next, turn on the gas supply and take a reading. If the manometer now reads 11 inches of water column, the thermostat is defective and must be replaced. If the by-pass screw test shows no change in pressure, the problem lies in the filter (See Sec. 6.2), the shut-off valve (See Sec. 6.1) or the gas supply (See Sec. 5). Shut off the gas supply, remove the by-pass screw, replace it with a proper one that has an o-ring and turn the gas on.

NOTE: Check for leaks with an approved LP gas leak solution whenever any part of the gas system has been worked on.

6.4 BY-PASS SCREW

The by-pass screw is a small brass screw located on any Dometic gas thermostat that regulates gas flow in the low flame mode. There are three common sizes of this screw: S-17 (350 BTU), S-14 (325 BTU) and S-11 (300 BTU). To check the by-pass screw, connect a manometer at the pressure test housing. The pressure on low flame mode should be 3 to 5 inches water column. Above 5 inches water column on low flame mode could cause an over-cooling situation. The by-pass screw used on the RM2604 and the RM2804 is S-14.

6.5 SAFETY VALVE

The safety valve is an assembly that shuts off the supply of LP gas to the burner if the flame goes out for any reason. This is to ensure that a concentration of unburned gas does not accumulate in the refrigerator vent area. To check the safety valve, use a known good thermocouple (See Sec. 6.6) and install into the safety valve. Next, supply flame to the tip of the thermocouple for 2 to 3 minutes while holding in on the safety valve stem. Next, remove flame from thermocouple tip and release safety valve stem. The safety valve should hold in for at least 30 seconds. If it releases earlier than 30 seconds, replace the safety valve.

6.6 THERMOCOUPLE

The thermocouple is a component extending above the burner assembly so the tip is in the path of the flame. It will produce 14 to 30 millivolts DC in normal operation. To check the thermocouple, use a known good safety valve (See Sec. 6.5) and attach to the thermocouple. Next, supply flame to the tip of the thermocouple for 2 to 3 minutes while depressing the safety valve. Remove the flame and release the safety valve. The valve should hold for at least 30 seconds. If it does not hold the safety valve open for 30 seconds, replace the thermocouple. If it does hold for 30 seconds or more, the thermocouple is good, do not replace it.

NOTE: Be sure the tip on the thermocouple is clean.

6.7 BURNER

The burner is a slotted metal tube located below the flue tube on the cooling unit. It should be level and the slots, in the burner, should be directly below the flue tube. The burner should be cleaned periodically, at least once a year. To clean the burner, remove from the refrigerator and check for any foreign residue that could cause a deflection of the gas flow or the flame. Next, soak the burner in an alcohol based solvent and allow to air dry. After cleaning, reinstall in the refrigerator.

6.8 FLUE BAFFLE

The flue baffle is designed to concentrate the heat, from the gas flame, at a certain area of the flue tube. It should be cleaned periodically, at least once a year. To clean, remove from the flue tube and check for any damage, then clean thoroughly. The length of the flue baffle assembly (flue baffle and wire) for the RM2604 is 31-9/16 inches and for the RM2804 is 37-1/8 inches. The flue baffle itself for the RM2604 is 3/4 inch wide and 5-1/4 inches long, for the RM2804 is 3/4 inch wide and 6 inches long. The proper baffle position for the RM2604 is 1-5/8 inches from the burner to the bottom of the baffle; for the RM2804 is 1-3/4 inches from the burner to the bottom of the baffle.

6.9 FLUE CAP

The flue cap is located at the top of the flue tube and is attached with a screw. It must be properly attached or flame outage could occur.

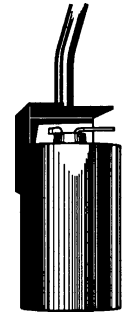

6.10 FLUE TUBE

The flue tube is a component of the cooling unit. It must be cleaned periodically, at least once a year. To clean, remove flue cap and flue baffle, then cover the burner and clean by using a flue brush. Dometic Part Number 0151404001. If the flue tube becomes coated with scale or residue from combustion of LP gas, the efficiency of gas operation decreases.

NOTE: After cleaning be sure to reinstall the flue baffle and flue cap.

6.11 ORIFICE

The orifice is a small brass fitting that has a ruby membrane that is laser beam drilled and is mounted on the gas line just prior to the burner. The orifice should be cleaned periodically, at least once a year, by using an alcohol based solvent and allowing to air dry. Never use a drill bit or jet tip cleaner to clean any orifice as these devices will damage the factory machined part and create a potentially dangerous condition. The correct orifice for the RM2604 is number 53 jet, for the RM2804 is number 58 jet.

NOTE: Always use the proper orifice. Never use a larger orifice as this could cause a lack of cooling problem.

SECTION 7 WIRING

7.1 EXTERNAL WIRING

1. **120 volts AC connection:** The refrigerator is equipped with a three prong (grounded) plug for protection against shock hazards and should be plugged directly into a properly grounded three prong receptacle. Do not cut or remove the grounding prong from this plug.
2. **12-volt connection for igniter and interior light:** The connection is made to the terminal block marked 12 volts DC REIGNITER-LAMP. The interior light and the igniter must be connected to a separate battery circuit and will draw about 1 amp at 12 volts DC.
3. **12-volt DC connection for heater (3-way models only):** This connection is made to the terminal block marked DC VOLT HEATER. The refrigerator must be connected to the battery circuit with two wires of

adequate capacity to avoid voltage drop. The wire gauge should be chosen with consideration to the wire length in accordance with the following table.

MAXIMUM TOTAL CONDUCTOR WIRE LENGTH IN FEET

AWG	RM2604	RM2804	Int. Light Only
10	17	17	55
8	27	27	85

Do not use the body or chassis of the vehicle as a substitute for either of the two conductors. No other electrical equipment or lighting should be connected to the refrigerator circuit. The refrigerator will draw 18 amps at 12 volts DC.

! CAUTION

DO NOT OPERATE THE REFRIGERATOR ON 12-VOLT WHEN THE VEHICLE IS PARKED. THE CUSTOMER WILL RUN OUT OF BATTERY IN A RATHER SHORT TIME. IF POSSIBLE, THE INSTALLATION OF A 12-VOLT OPERATED REFRIGERATOR SHOULD BE COMPLETED WITH A RELAY MOUNTED EITHER IN THE TOW VEHICLE OR IN THE RECREATIONAL VEHICLE. THIS RELAY WILL AUTOMATICALLY CUT OUT THE REFRIGERATOR WHEN THE MOTOR IS STOPPED.

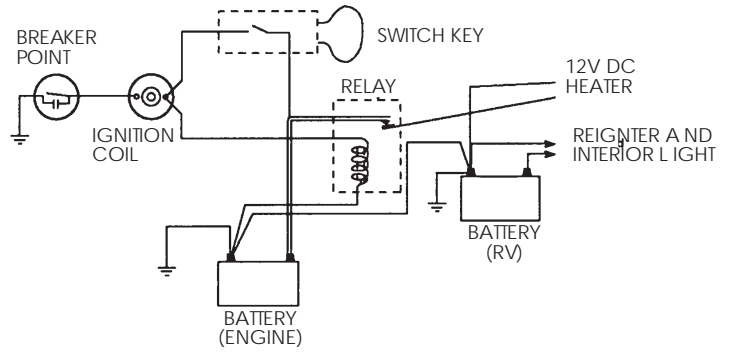

7.2 INTERNAL WIRING

Check all wires and the connectors to ensure a proper and tight connection. Also verify the refrigerator is wired per the wiring diagram for the model you are working on. (See wiring diagram below and on the next page.)

RM2604 & RM2804 2-WAY 120 VOLTS

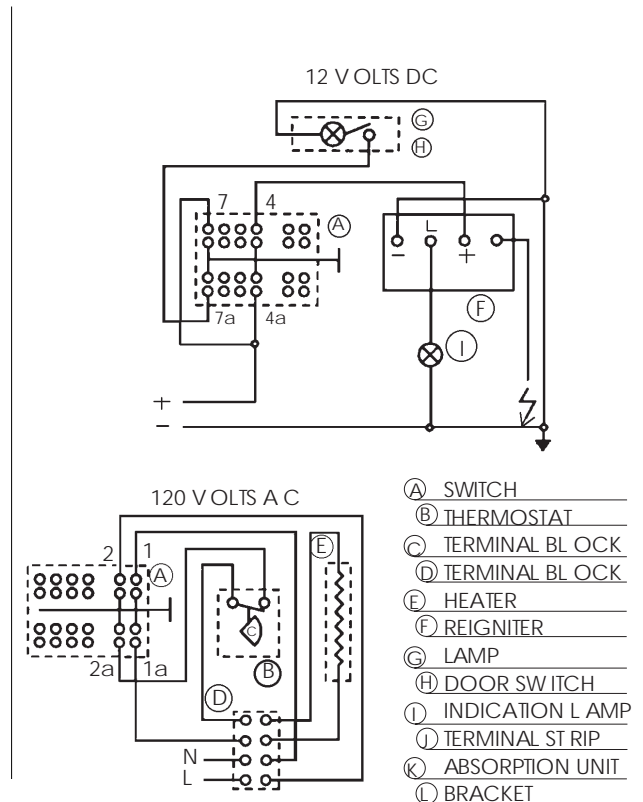
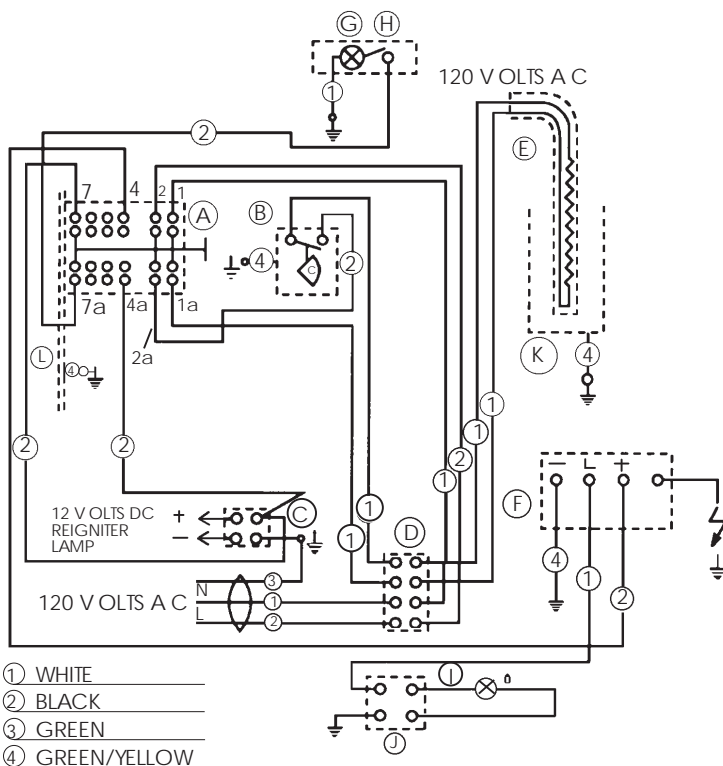

RM2604 & RM2804 3-WAY 12/120 VOLTS

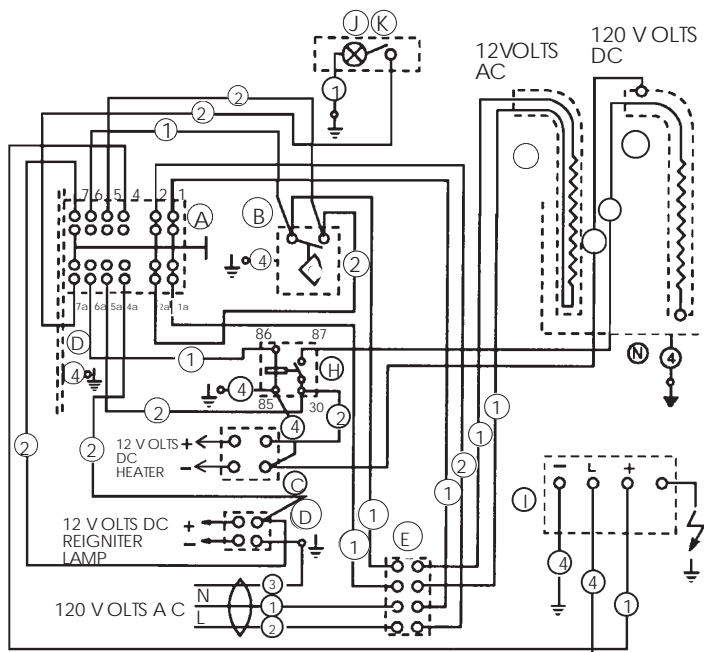

- ① WHITE
- ② BLACK
- ③ GREEN
- ④ GREEN/YELLOW

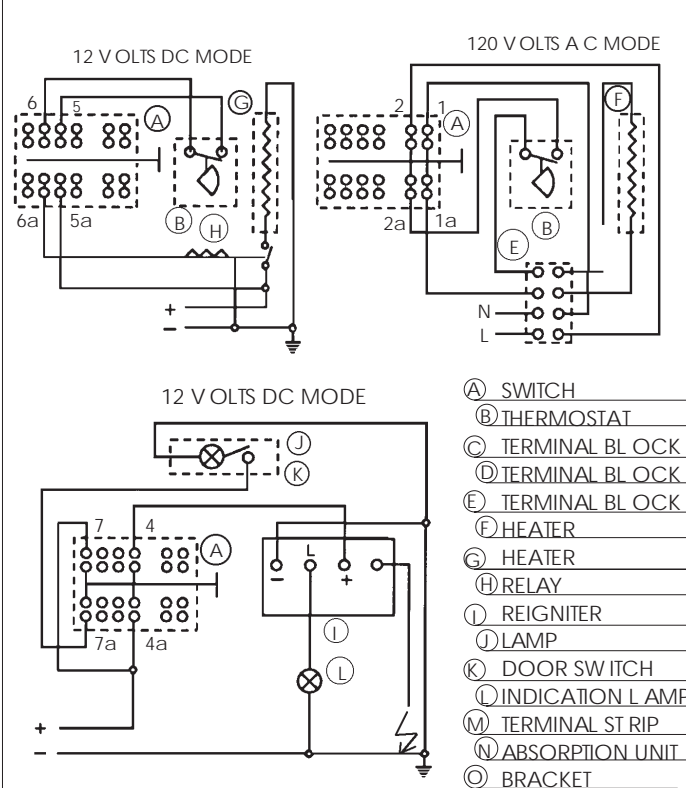

- Ⓐ SWITCH
- Ⓑ THERMOSTAT
- Ⓒ TERMINAL BLOCK
- Ⓓ TERMINAL BLOCK
- Ⓔ TERMINAL BLOCK
- Ⓕ HEATER
- Ⓖ HEATER
- Ⓗ RELAY
- Ⓘ REIGNITER
- Ⓝ LAMP
- Ⓚ DOOR SWITCH
- Ⓛ INDICATION LAMP
- Ⓝ TERMINAL STRIP
- Ⓞ ABSORPTION UNIT
- Ⓟ BRACKET

**SECTION 8
OTHER**

8.1 LEVELING

Leveling is one of the requirements for proper operation with absorption refrigerators. The absorption design utilizes no mechanical pumps or compressors to circulate the refrigerant within the system, so proper leveling must be maintained to provide the correct refrigerant flow. Without proper leveling, refrigerant within the cooling unit will collect and stagnate at certain areas. Without proper refrigerant flow, the cooling process will stop. The RM2604 and RM2804 has a type of cooling unit that utilizes an enclosed pump tube surrounded by a solution to protect the assembly. To insure proper leveling with these models, the vehicle needs to be leveled so it is comfortable to live in. (No noticeable sloping of floor or walls). When the vehicle is moving, leveling is not critical as the rolling and pitching movement of the vehicle will pass to either side of level, keeping the refrigerant from accumulating in the piping.

8.2 VENTILATION

Ventilation is one of the requirements for proper cooling unit operation. The coach vent system must be able to provide a way to direct the hot air, produced by the action of the cooling unit, out away from the installation

of the refrigerator. The refrigerator extracts heat from the interior of the refrigerator cabinet and dissipates the heat out through the vent system. In a proper installation there should be as little open space as possible surrounding the sides and top of the refrigerator to achieve proper air flow. All potential dead air pockets should be blocked or baffled to insure that heat won't be trapped in these spaces and reduce efficiency. In addition, the cooling unit should be at least one half (1/2) inch from the nearest surface made of combustible material.

NOTE: Refrigerators should be installed in accordance with appropriate installation instructions received with the refrigerator.

8.3 AIR LEAKS

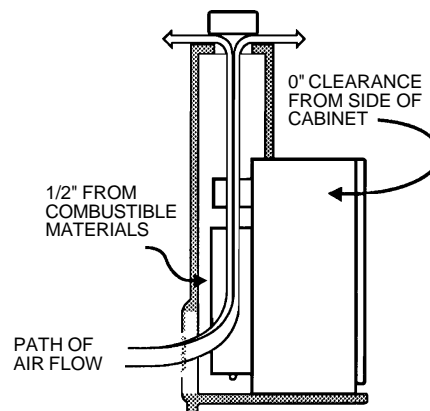

Check the gasket on the doors to be sure of a positive air seal. A simple method to check gaskets is to close the door on a dollar bill, then pull the dollar bill out. If no resistance is felt, the gasket is not sealing properly. This should be done on all four sides of the door. If a gasket is not sealing properly, first warm the gasket material with a hair dryer.

! CAUTION
DO NOT OVERHEAT
AS YOU CAN MELT THE MATERIAL.

Then close the door and the magnetic strip should pull the gasket to the metal frame. Leave door closed until the material has cooled. Then re-check for a positive seal. If a positive seal cannot be achieved, replace the door gasket. Also check that the cooling unit is installed properly. The cooling unit's foam block, the portion that surrounds the evaporator coils, must be flush to the cabinet at the back of the refrigerator and have a positive seal. If the cooling unit is not installed properly, remove and install properly.

NOTE: Air leaks will cause insufficient cooling as well as rapid formation of frost.

8.4 DOOR POSITION

The door position can be checked by observing any misalignment of the door in relation to the frame.

To correct an

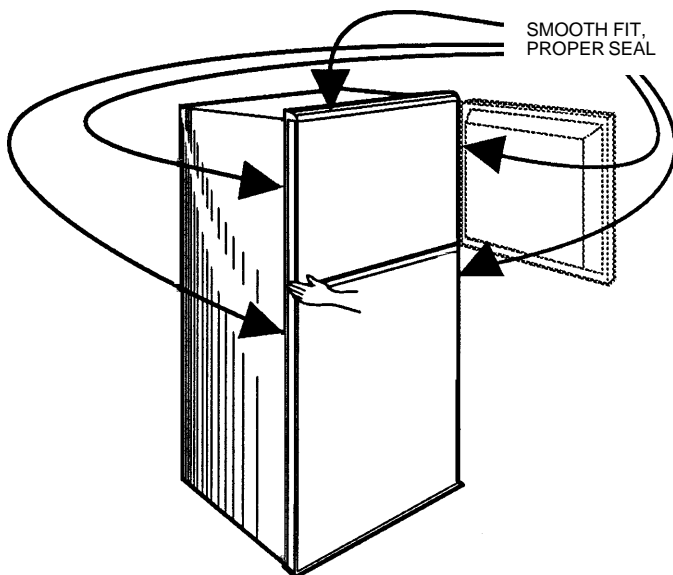

alignment of the door, loosen the hinge screws slightly, and re-orient the door in the proper position. Hold the door in its new position and carefully retighten the hinge screws.

If the door needs more adjustment than is available through the hinge adjustment, the base can be repositioned to re-orient the door.

Turn the refrigerator on its side to gain access to the two front base screws. Loosen both screws slightly. Reposition the base until the door is re-oriented. Re-tighten the base screws while holding the base in its new position.

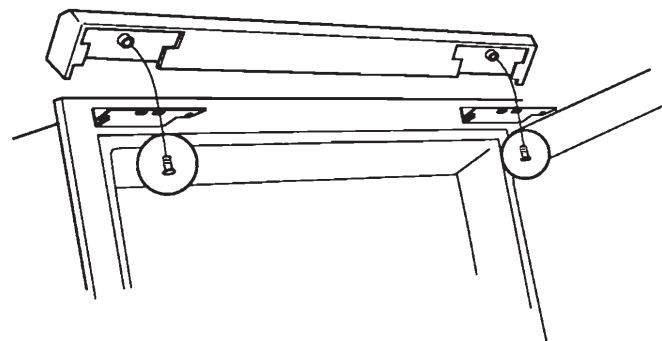
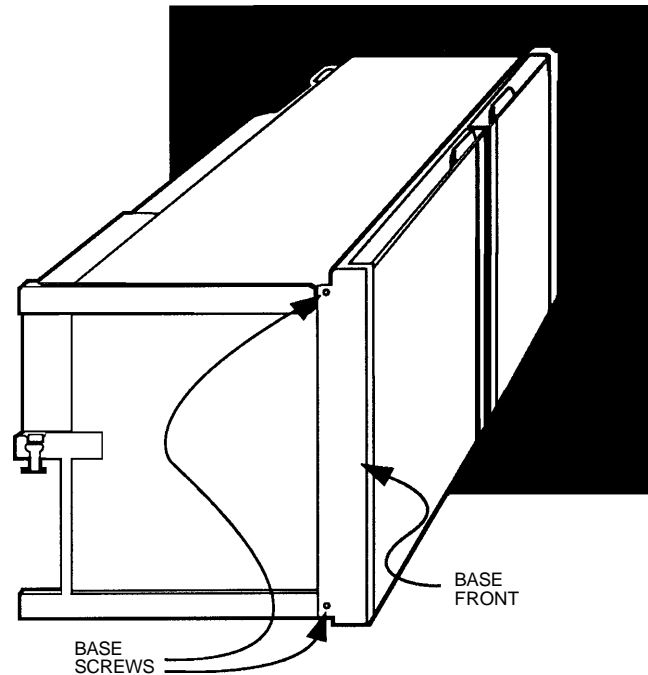

NOTE: Improper position of the lower door can cause the interior light to stay on when door is closed.

8.5 AMBIENT TEMPERATURE

This is the temperature surrounding the recreational vehicle, as well as the temperature of air at the back of the refrigerator. As the ambient temperature increases, the air temperature in the area of the cooling unit increases. Improper venting at this point, will cause the cooling unit to have reduced efficiency.

8.6 COOLING UNIT

The cooling unit is a self-contained, hermetically sealed set of coils where the refrigeration process takes place. The chemicals involved in the cooling process include hydrogen, ammonia, water and a rust inhibiting agent. There are no repairs recommended on the cooling unit. If it is defective, replace with a new cooling unit. To check the cooling unit, first verify the AC heating element is good (See Sec. 2.1). Then place approximately one gallon of water inside the refrigerator and place a thermometer in one of the containers of water. Next, supply 115 volts direct to the AC heating element and operate for at least 12 hours. Then check the temperature on the thermometer. It should be at 45 degrees or lower depending on test conditions (See ambient temperature Sec. 8.5). If so, the cooling unit is good. If the temperature of the water is above 45 degrees, replace the cooling unit.

8.7 FOOD STORAGE

Proper refrigeration requires free air circulation within the food storage compartment. Restricted air circulation within this compartment will cause higher cabinet temperatures. To remedy this situation, simply rearrange your foodstuffs. It is also essential that the shelves are not covered with paper or large storage containers. Always remember to allow for proper air circulation. Odorous or highly flavored foods should always be stored in covered dishes, plastic bags or wrapped in foil or waxed paper to prevent food odors. Vegetables,

lettuce, etc., should be covered to retain their crispness. NEVER PUT HOT FOOD INTO THE REFRIGERATOR. To reduce frost formation in and on the freezing compartment, cover stored liquids and moist foods and do not leave the door open longer than necessary. When the refrigerator is heavily loaded, it takes a longer time for refrigerator temperatures to lower, also increasing the ice making time. A very heavy load may also cause defrosting.

8.8 HIGH HUMIDITY

High humidity may cause a small amount of condensation to form on the frame of the refrigerator. In some cases it can develop to such a degree that it will run off the frame. As the humidity is reduced, the sweating will decrease. High humidity can also be a factor in rapid formation of frost.

8.9 INTERIOR LINER SEAL TO FRAME

There is a seal that is applied to the liner in the area where the metal frame makes contact with the interior liner. If this seal is incomplete, cold air can migrate out to the metal frame. If this happens, condensation could form on the frame and could promote rapid formation of frost. If you suspect an improper seal, apply a small bead of silicone all the way around the perimeter where the frame meets the interior liner.